

## Venus-TA

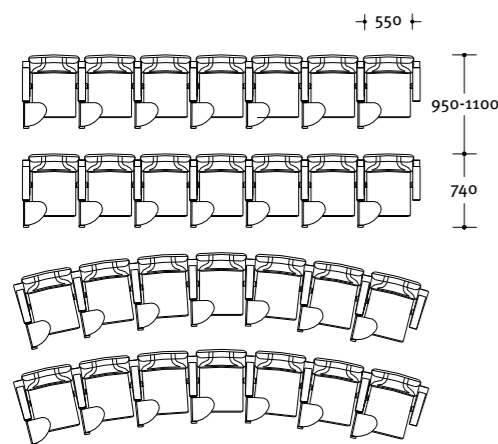
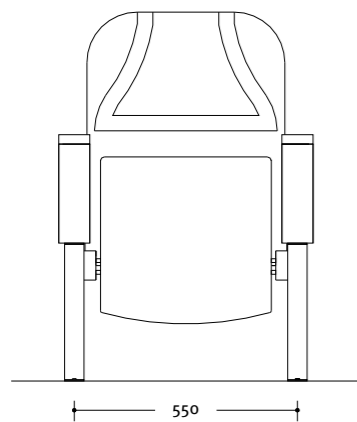
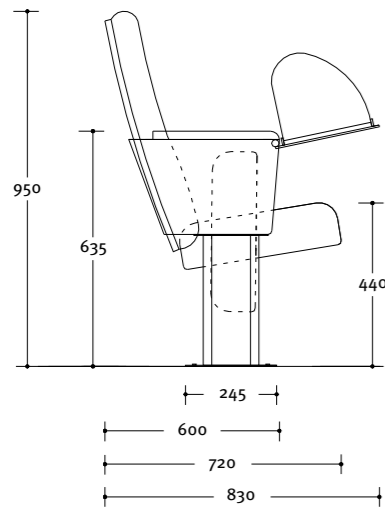

## Technical Specifications

### Seat:

The inner seat frame is made of sheet metal, 2 mm thick, supplied with two cylindrical solid pivots to a chive easily a replaceable tip – up seat with counter weight mechanism.

For more comfort, the seat frame is padded by cut foam with the following features:

- Color gray.
- Density: 28-29 Kg/m<sup>3</sup>.
- Tension force: max. 100N.
- Compression force: max. 126N
- Elongation: max. 200%.

Seat is completely upholstered with high quality fabric for Auditorium chairs.

### Back Rest:

Back rest is made of plywood pressed by special high frequency generator machines to produce the final requested shape, padded with cut foam with the same specs as the seat.

Backrest is completely upholstered with Fabric, in high quality, suitable for Auditorium chairs. Back rest supplied with beech veneers cover.

### Pedestal Sides & Arm Rest:

Upper part (Arm rest) supplied with cover made of beech veneers pressed by special high frequency generator machines. Armrest is designed to have a folding writing pad.

Lower part (Pedestal sides) is made of a powder coated formed metal sheet 0.9 mm thick, padded with fabric, supplied with fixing piece fixed to the ground by using roll-plugs & screws.

### Writing pad:

Made of wood and laminated by the HPL on both sides, hidden inside the Arm rest.

### Fabric:

Imported from the UK with following features

Composition:

- 100% Polyolefin.
- Weight: 230 g/m<sup>2</sup> + 5%(320g/lin.m.+5%).
- Width: 140cm + 2% usable.
- Abrasion: Grade A tested in accordance with EN 14465 :2003
- Flammability: BS EN 1021- 1 :2006 (Cigarette)
- Light fastness: 6 (Iso 105-Bo2:1999).
- Fastness to rubbing: Wet:4 Dry: 4 (Iso 105- x12:2002).

## Venus - TA



- Seat and back are padded with cut foam, completely upholstered with fabric.
- Back covered with varnished multilayered beech wood.
- Easily replaceable tip-up seat with counter weight mechanism.
- Sides made of sheet metal, powder coated padded with fabric.
- Arm rest made of varnished multilayered beech wood.
- All metal structure, powder coated.
- Folding, writing table hidden inside the arm rest

